

Electric Mixer

Model No:BR6307

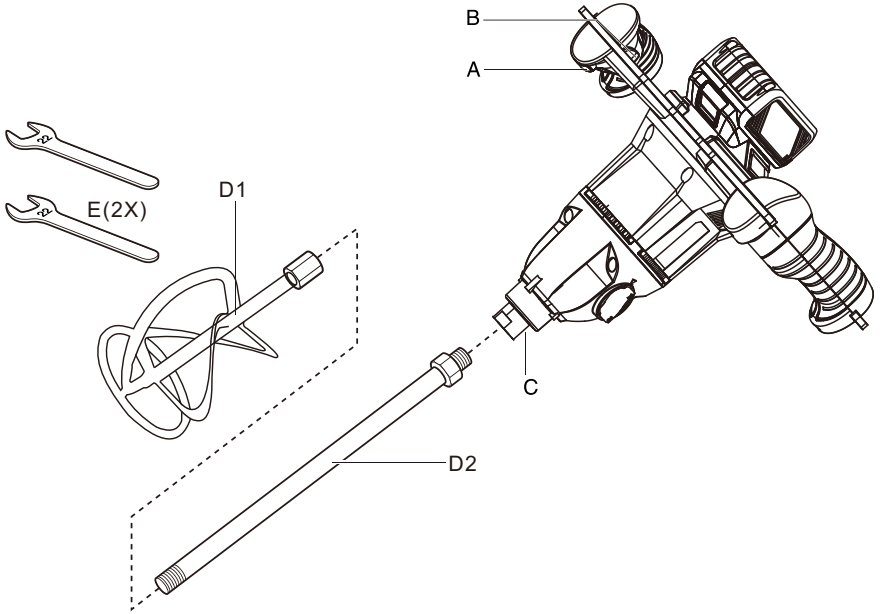

①



A Switch for on/off and speed control
C Spindle
E Wrench (2)

B Lock-off button
D Mixing paddle

②

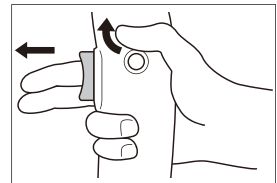
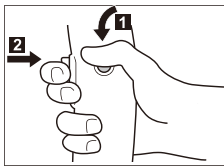

③

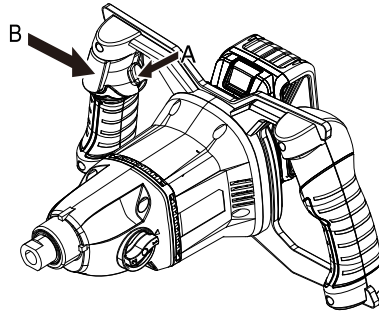

④

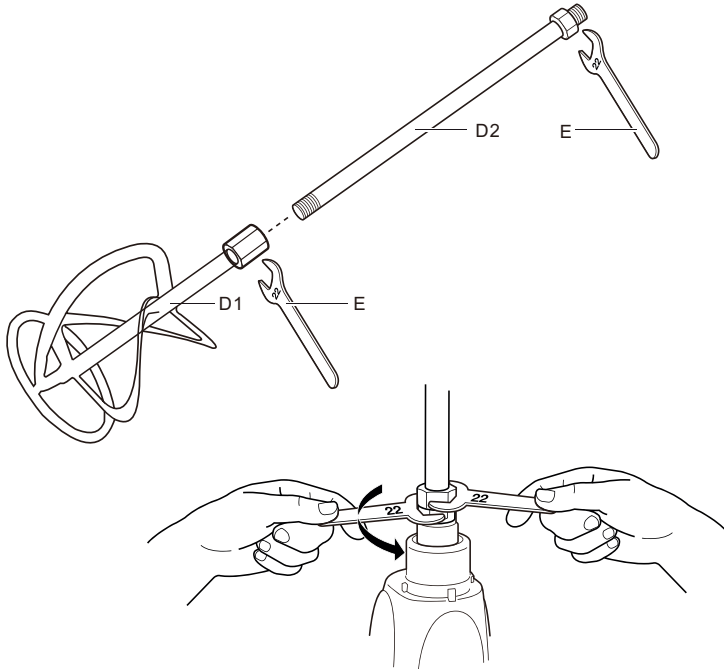

TECHNICAL SPECIFICATIONS

Model Number	BR6307
Voltage	18V
No-load Speed	0-450/0-720 min ⁻¹
Mixing paddle Dia. Ø max	120mm
Coupling thread	M14 x 2
Protection class	II □

WARNING! Read all safety warning and all instruction. Failure to follow the warning and instruction may result in electric shock, fire and /or serious injury.



WARNING: To reduce the risk of injury, read the instruction manual

GENERAL POWER TOOL SAFETY WARNINGS

 **WARNING!** Read all safety warnings and all instructions may result in electric shock, fire and /or serious injury.

SAVE ALL WARNINGS AND INSTRUCTIONS FOR FUTURE REFERENCE

The term 'power tool' in the warnings refers to your mains-operated (corded) power tool or battery-operated (cordless) power tool.

1. Work Area Safety

- > **Keep work area clean and well lit.** Cluttered or dark areas invite accidents
- > **Do not operate power tools in explosive atmospheres, such as in the presence of flammable liquids, gases or dust.** Power tools create sparks which may ignite the dust or fumes.
- > **keep children and bystanders away while operating a power tool.** Distractions can cause you to lose control.

2. Electrical Safety

- > **Power tool plugs must match the outlet. Never modify the plug in any way. Do not use any adapter plugs with earthed (grounded) power tools.** Unmodified plugs and matching outlets will reduce risk of electric shock.
- > **void body contact with earthed or grounded surfaces such as pipes, radiators, ranges and refrigerators.** There is an increased risk of electric shock if your body is earthed or grounded.
- > **Do not expose power tools to rain or wet conditions.** Water entering a power tool will increase the risk of electric shock.
- > **Do not abuse the cord. Never use the cord for carrying, pulling or unplugging the power tool. Keep cord away from heat, oil, sharp edges or moving parts.** Damaged or entangled cords increase the risk of electric shock.
- > **When operating a power tool outdoors, use an extension cord suitable for outdoor use.** Use of a cord suitable for outdoor use reduces the risk of electric shock.
- > **If operating a power tool in a damp location is unavoidable, use a residual current device (RCD) protected supply.** Use of an RCD reduces the risk of electric shock.

3. Personal safety

- > **Stay alert, watch what you are doing and use common sense when operating a power tool. Do not use a power tool while you are tired or under the influence of drugs, alcohol or medication.** A moment of inattention while operating power tools may result in serious personal injury.
- > **Use personal protective equipment. Always wear eye protection.** Protective equipment such as dust mask, non-skid safety shoes, hard hat, or hearing protection used for appropriate conditions will reduce personal injuries.
- > **Prevent unintentional starting. Ensure the switch is in the off position before connecting to power source and/or battery pack, picking up or carrying the tool.** Carrying power tools with your finger on the switch or energising power tools that have the switch on invites accidents.
- > **Remove any adjusting key or wrench before turning the power tool on.** A wrench or a key left attached to a rotating part of the power tool may result in personal injury.
- > **Do not overreach. Keep proper footing and balance at all times.** This enables better control of the power tool in unexpected situations.
- > **Dress properly. Do not wear loose clothing or jewellery. Keep your hair, clothing and gloves away from moving parts.** Loose clothes, jewellery or long hair can be caught in moving parts.
- > **If devices are provided for the connection of dust extraction and collection facilities, ensure these are connected and properly used.** Use of dust collection can reduce dust-related hazards.
- > **Do not let familiarity gained from frequent use of tools allow you to become complacent and ignore tool safety principles.** A careless action can cause severe injury within a fraction of a second.

4. Power tool use and care

- > **Do not force the power tool. Use the correct power tool for your application.** The correct power tool will do the job better and safer at the rate for which it was designed..
- > **Do not use the power tool if the switch does not turn it on and off.** Any power tool that cannot be controlled with the switch is dangerous and must be repaired.
- > **Disconnect the plug from the power source and/ or remove the battery pack, if detachable, from the power tool before making any adjustments, changing accessories, or storing power tools.** Such preventive safety measures reduce the risk of starting the power tool accidentally.
- > **Store idle power tools out of the reach of children and do not allow persons unfamiliar with the power tool or these instructions to operate the power tool.** Power tools are dangerous in the hands of untrained users.

- > **Maintain power tools and accessories. Check for misalignment or binding of moving parts, breakage of parts and any other condition that may affect the power tool's operation. If damaged, have the power tool repaired before use.** Many accidents are caused by poorly maintained power tools.
- > **Keep cutting tools sharp and clean.** Properly maintained cutting tools with sharp cutting edges are less likely to bind and are easier to control.
- > **Use the power tool, accessories and tool bits etc., in accordance with these instructions taking into account the working conditions and the work to be performed.** Use of the power tool for operations different from those intended could result in a hazardous situation.
- > **Keep handles and grasping surfaces dry, clean and free from oil and grease.** Slippery handles and grasping surfaces do not allow for safe handling

5. Battery tool use and care

- > **Recharge only with the charger specified by the manufacturer.** A charger that is suitable for one type of battery pack may create a risk of fire when used with another battery pack.
- > **Use power tools only with specifically designated battery packs.** Use of any other battery packs may create a risk of injury and fire.
- > **When battery pack is not in use, keep it away from other metal objects like paper clips, coins, keys, nails, screws or other small metal objects that can make a connection from one terminal to another.** Shorting the battery terminals together may cause burns or a fire.
- > **Under abusive conditions, liquid may be ejected from the battery; avoid contact. If contact accidentally occurs, flush with water. If liquid contacts eyes, additionally seek medical help.** Liquid ejected from the battery may cause irritation or burns.
- > **Do not use a battery pack or tool that is damaged or modified.** Damaged or modified batteries may exhibit unpredictable behaviour resulting in fire, explosion or risk of injury.
- > **Do not expose a battery pack or tool to fire or excessive temperature.** Exposure to fire or temperature above 130 °C may cause explosion.
- > **Follow all charging instructions and do not charge the battery pack or tool outside the temperature range specified in the instructions.** Charging improperly or at temperatures outside the specified range may damage the battery and increase the risk of fire.

6. Service

- > **Have your power tool serviced by a qualified repair person using only identical replacement parts.** This will ensure that the safety of the power tool is maintained.
- > **Never service damaged battery packs.** Service of battery packs should only be performed by the manufacturer or authorized service providers.

Residual Risks

In spite of the application of the relevant safety regulations and the implementation of safety devices, certain residual risks cannot be avoided. These are:

- Impairment of hearing.
- Risk of personal injury due to flying particles.
- Risk of burns due to accessories becoming hot during operation.
- Risk of personal injury due to prolonged use.
- A concentration of dust which is harmful to health when working in an area that is not sufficiently ventilated.

Electrical Safety

The electric motor has been designed for one voltage only. Always check that the battery pack voltage corresponds to the voltage on the rating plate. Also make sure that the voltage of your charger corresponds to that of your mains.

Using an Extension Cable

An extension cord should not be used unless absolutely necessary. Use an approved extension cable suitable for the power input of your charger (see Technical Data). The minimum conductor size is 1 mm²; the maximum length is 30 m. When using a cable reel, always unwind the cable completely.

SAVE THESE INSTRUCTIONS

Important Safety Instructions for All Battery Chargers

SAVE THESE INSTRUCTIONS: This manual contains important safety and operating instructions for compatible battery chargers (refer to Technical Data). Before using charger, read all instructions and cautionary markings on charger, battery pack, and product using battery pack.

WARNING: Shock hazard. Do not allow any liquid to get inside charger. Electric shock may result.

WARNING: We recommend the use of a residual current device with a residual current rating of 30mA or less.

CAUTION : Burn hazard. To reduce the risk of injury, charge only POWERPLUS rechargeable batteries. Other types of batteries may burst causing personal injury and damage.

CAUTION: Children should be supervised to ensure that they do not play with the appliance.

NOTICE: Under certain conditions, with the charger plugged into the power supply, the exposed charging contacts inside the charger can be shorted by foreign material. Foreign materials of a conductive nature such as, but not limited to, steel wool, aluminum foil or any buildup of metallic particles should be kept away from charger cavities. Always unplug the charger from the power supply when there is no battery pack in the cavity. Unplug charger before attempting to clean .

DO NOT attempt to charge the battery pack with any chargers other than the ones in this manual. The charger and battery pack are specifically designed to work together

These chargers are not intended for any uses other than charging POWERPLUS rechargeable batteries. Any other uses may result in risk of fire, electric shock or electrocution.

Do not expose charger to rain or snow.

Pull by plug rather than cord when disconnecting charger. This will reduce risk of damage to electric plug and cord.

Make sure that cord is located so that it will not be stepped on, tripped over, or otherwise subjected to damage or stress.

Do not use an extension cord unless it is absolutely necessary. Use of improper extension cord could result in risk of fire, electric shock, or electrocution.

Do not place any object on top of charger or place the charger on a soft surface that might block the ventilation slots and result in excessive internal heat. Place the charger in a position away from any heat source. The charger is ventilated through slots in the top and the bottom of the housing.

Do not operate charger with damaged cord or plug—have them replaced immediately.

Do not operate charger if it has received a sharp blow, been dropped, or otherwise damaged in any way. Take it to an authorised service centre.

Do not disassemble charger; take it to an authorised service centre when service or repair is required. Incorrect reassembly may result in a risk of electric shock, electrocution or fire.

In case of damaged power supply cord the supply cord must be replaced immediately by the manufacturer, its service agent or similar qualified person to prevent any hazard.

Disconnect the charger from the outlet before attempting any cleaning. This will reduce the risk of electric shock. Removing the battery pack will not reduce this risk.

NEVER attempt to connect two chargers together.

- The charger is designed to operate on standard 230V household electrical power. Do not attempt to use it on any other voltage. This does not apply to the vehicular charger.

Charging a Battery

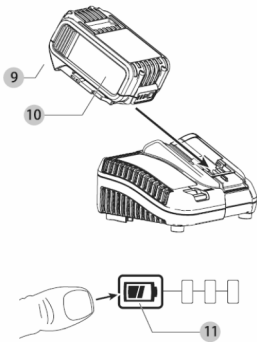

1. Plug the charger into an appropriate outlet before inserting battery pack
2. Insert the battery pack 10 into the charger, making sure the battery pack is fully seated in the charger. The red (charging) light will blink repeatedly indicating that the charging process has started.
3. The completion of charge will be indicated by the red light remaining ON continuously. The battery pack is fully charged and may be used at this time or left in the charger. To remove the battery pack from the charger, push the battery release button 9 on the battery pack.

NOTE: To ensure maximum performance and life of lithium-ion battery packs, charge the battery pack fully before first use.

Charger Operation

Refer to the indicators below for the charge status of the battery pack.

Charge Indicators



* The red light will continue to blink, but a yellow indicator light will be illuminated during this operation. Once the battery pack has reached an appropriate temperature, the yellow light will turn off and the charger will resume the charging procedure.

The compatible charger(s) will not charge a faulty battery pack. The charger will indicate faulty battery by refusing to light or by displaying problem pack or charger blink pattern.

NOTE: This could also mean a problem with a charger.

If the charger indicates a problem, take the charger and battery pack to be tested at an authorised service centre.

Additional Safety Rules for Paddle Mixers

- > **Hold the tool with both hands at the intended handles.** Loss of control can cause personal injury.
- > **Ensure sufficient ventilation when mixing flammable materials to avoid a hazardous atmosphere.** Developing vapour may be inhaled or be ignited by the sparks the power tool produces.
- > **Do not mix food.** Power tools and their accessories are not designed for processing food.
- > **Ensure the mixing container is placed in a firm and secure position.** A container that is not properly secured may move unexpectedly.
- > **Follow the instructions and warnings for the material to be mixed.** Material to be mixed may be harmful.
- > **Do not reach into the mixing container with your hands or insert any other objects into it while mixing.** Contact with the mixer basket may lead to serious personal injury.
- > **Start up and run down the tool in the mixing container only.** The mixer basket may bend or spin in an uncontrolled manner.
- > **Take into account that there will be a reactionary torsional momentum.**
- > **Load the machine in such a way that the speed does not decrease too much or the machine is forced to stop.**

- > **When working with dust, you must wear respiratory protection.** Inhaling the dust may damage the respiratory tract.
- > **If the power tool falls into the material to be mixed, remove the battery immediately and have the tool and battery checked by a qualified repair person.**

OPERATION



WARNING: Always observe the safety instructions and applicable regulations.



WARNING: To reduce the risk of serious personal injury, turn tool off and disconnect battery pack before making any adjustments or removing/ installing attachments or accessories. An accidental start-up can cause injury.



Running the Mixer

Always check the flammability warnings on any product before attempting to use

To install the battery 10 into the tool handle, align the battery pack with the rails inside the tool's handle and slide it into the handle until the battery pack is firmly seated in the tool and ensure that it does not disengage.

1. Insert the paddle thread into paddle holder 4 by turning it clockwise.
2. Tighten the paddle with the 2 included wrenches.
3. To remove the paddle, proceed in reverse order.
4. Hold the mixer with both hands.
5. To start the unit, press the switch 1 and press lock off function 2, turning on the unit.
6. To stop the tool, release the trigger.

During the mixing process you should guide the mixer around the container to ensure a more consistent mix. Continue until all of the material is completely mixed.

NOTE: Please follow the processing instructions of the manufacturer of the material.



Always be aware that the greater the viscosity of the material, the greater the impact of the torque forces on the mixer.



CAUTION: If the mixer comes into contact with the surface of the mixing container while running, it may kick back.

Variable Speed



WARNING: Always switch off the tool when work is finished and before removing the battery.

The adhesive's rate of flow is controlled by the variable speed 3 to accommodate various applications.

Pack s speed by turning the dial to desired setting.

Note: "1" is the lowest (slowest) setting and "6" is the highest (fastest) setting.

In addition to the variable speed dial, the material's rate of flow is also controlled with a variable speed trigger.

1. Squeeze the trigger switch 7 to turn the tool on

Note: the further the trigger is depressed the faster the rate of flow

2. Release the trigger switch to turn the tool off

Trigger Switch Lock-off

Your tool is equipped with a trigger switch lock-off to safeguard against inadvertent release of material.

1. To lock the trigger switch, push trigger switch lock off. The tool will not operate with the switch in the locked position.

2. To unlock the trigger switch, push the trigger switch lock-off down.

MAINTENANCE

Your power tool has been designed to operate over a long period of time with a minimum of maintenance. Continuous satisfactory operation depends upon proper tool care and regular cleaning.



WARNING: To reduce the risk of serious personal injury, turn tool off and disconnect battery pack before making any adjustments or removing/ installing attachments or accessories. An accidental start-up can cause injury.



Protecting the Environment

Separate collection. Products and batteries marked with this symbol must not be disposed of with normal household waste. Products and batteries contain materials that can be recovered or recycled reducing the demand for raw materials. Please recycle electrical products and batteries according to local provisions

Rechargeable Battery Pack

This long life battery pack must be recharged when it fails to produce sufficient power on jobs which were easily done before. At the end of its technical life, discard it with due care for our environment:

Run the battery pack down completely, then remove it from the tool.

Li-Ion cells are recyclable. Take them to your dealer or a local recycling station. The collected battery packs will be recycled or disposed of properly.