

# Cordless Polisher

**Model No:BR7173**

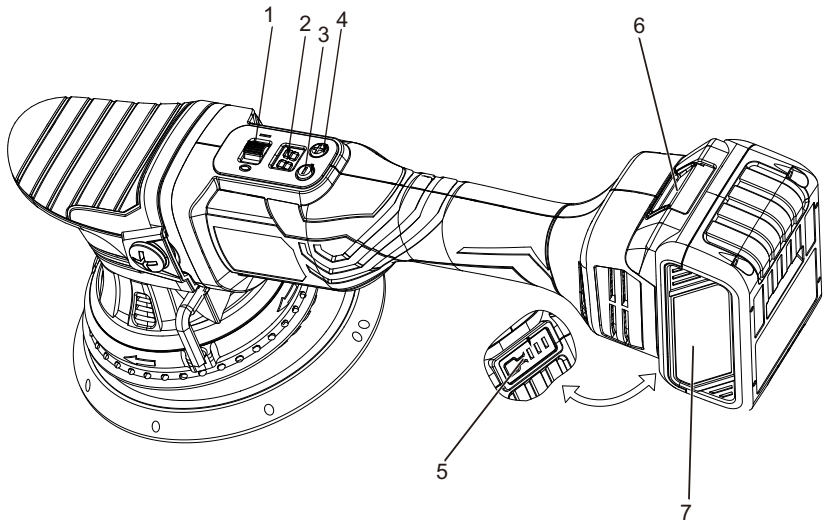

①



1. On-off Switch

2. Digital Display

3. Speed Deduction Button

4. Speed Increase Button

5. LED for electric charge volume

6. Battery Release Button

7. Battery pack

## Technical Data

<b>Voltage:</b>	18V
<b>Battery type:</b>	Li-Ion
<b>No Load Speed:</b>	2100-5000rpm
<b>Pad Size:</b>	Dia. 125mm
<b>Out-put Shaft:</b>	M8

# **SAFETY**

## **GENERAL SAFETY INSTRUCTIONS**



**WARNING!** Read all safety warnings and all instructions. Failure to follow the warnings and instructions may result in electric shock, fire and/or serious injury. Save all warnings and instructions for future reference. The term “power tool” in the warnings refers to your mainsoperated (corded) power tool or battery-operated (cordless) power tool.

### **1.WORK AREA SAFETY**

- > Keep work area clean and well lit. Cluttered or dark areas invite accidents.
- > Do not operate power tools in explosive atmospheres, such as in the presence of flammable liquids, gases or dust. Power tools create sparks which may ignite the dust or fumes.
- > Keep children and bystanders away while operating a power tool. Distractions can cause you to lose control.

### **2.ELECTRICAL SAFETY**

- > Power tool plugs must match the outlet. Never modify the plug in any way. Do not use any adapter plugs with earthed (grounded) power tools. Unmodified plugs and matching outlets will reduce risk of electric shock.
- > Avoid body contact with earthed or grounded surfaces such as pipes, radiators, ranges and refrigerators. There is an increased risk of electric shock if your body is earthed or grounded.
- > Do not expose power tools to rain or wet conditions. Water entering a power tool will increase the risk of electric shock.
- > Do not abuse the cord. Never use the cord for carrying, pulling or unplugging the power tool. Keep cord away from heat, oil, sharp edges or moving parts. Damaged or entangled cords increase the risk of electric shock.
- > When operating a power tool outdoors, use an extension cord suitable for outdoor use. Use of a cord suitable for outdoor use reduces the risk of electric shock.
- > If operating a power tool in a damp location is unavoidable, use an earth leakage circuit breaker. Use of an earth leakage circuit breaker reduces the risk of electric shock.

### **3.PERSONAL SAFETY**

- > Stay alert, watch what you are doing and use common sense when operating a power tool. Do not use a power tool while you are tired or under the influence of drugs, alcohol or medication. A moment of inattention while operating power tools may result in serious personal injury.

- > Use personal protective equipment. Always wear eye protection. Protective equipment such as dust mask, non-skid safety shoes, hard hat, or hearing protection used for appropriate conditions will reduce personal injuries.
- > Prevent unintentional starting. Ensure the switch is in the off-position before connecting to power source and/or battery pack, picking up or carrying the tool. Carrying power tools with your finger on the switch or energising power tools that have the switch on invites accidents.
- > Remove any adjusting key or wrench before turning the power tool on. A wrench or a key left attached to a rotating part of the power tool may result in personal injury.
- > Do not overreach. Keep proper footing and balance at all times. This enables better control of the power tool in unexpected situations.
- > Dress properly. Do not wear loose clothing or jewelry. Keep your hair, clothing and gloves away from moving parts. Loose clothes, jewelry or long hair can be caught in moving parts.
- > If devices are provided for the connection of dust extraction and collection facilities, ensure these are connected and properly used. Use of dust collection can reduce dust-related hazards.

#### **4. POWER TOOL USE AND CARE**

- > Do not force the power tool. Use the correct power tool for your application. The correct power tool will do the job better and safer at the rate for which it was designed.
- > Do not use the power tool if the switch does not turn it on and off. Any power tool that cannot be controlled with the switch is dangerous and must be repaired.
- > Disconnect the plug from the power source and/or the battery pack from the power tool before making any adjustments, changing accessories, or storing power tools. Such preventive safety measures reduce the risk of starting the power tool accidentally.
- > Store idle power tools out of the reach of children and do not allow persons unfamiliar with the power tool or these instructions to operate the power tool. Power tools are dangerous in the hands of untrained users.
- > Maintain power tools. Check for misalignment or binding of moving parts, breakage of parts and any other condition that may affect the power tool's operation. If damaged, have the power tool repaired before use. Many accidents are caused by poorly maintained power tools.
- > Keep cutting tools sharp and clean. Properly maintained cutting tools with sharp cutting edges are less likely to bind and are easier to control.
- > Use the power tool, accessories and tool bits etc., in accordance with these instructions, taking into account the working conditions and the work to be performed. Use of the power tool for operations different from those intended could result in a hazardous situation.

## 5.SERVICE

> Have your power tool serviced by a qualified repair person using only identical replacement parts. This will ensure that the safety of the power tool is maintained.

**SAVE THESE INSTRUCTIONS:** This manual contains important safety and operating instructions for compatible battery chargers (refer to Technical Data). Before using charger, read all instructions and cautionary markings on charger, battery pack, and product using battery pack.



**WARNING:** Shock hazard. Do not allow any liquid to get inside charger. Electric shock may result.

**WARNING:** We recommend the use of a residual current device with a residual current rating of 30mA or less.

**CAUTION :**Burn hazard. To reduce the risk of injury, charge only rechargeable batteries. Other types of batteries may burst causing personal injury and damage.

**CAUTION:** Children should be supervised to ensure that they do not play with the appliance.

**NOTICE:** Under certain conditions, with the charger plugged into the power supply, the exposed charging contacts inside the charger can be shorted by foreign material. Foreign materials of a conductive nature such as, but not limited to, steel wool, aluminum foil or any buildup of metallic particles should be kept away from charger cavities. Always unplug the charger from the power supply when there is no battery pack in the cavity. Unplug charger before attempting to clean .

**DO NOT attempt to charge the battery pack with any chargers other than the ones in this manual.** The charger and battery pack are specifically designed to work together

**These chargers are not intended for any uses other than charging rechargeable batteries.** Any other uses may result in risk of fire, electric shock or electrocution.

**Do not expose charger to rain or snow.**

**Pull by plug rather than cord when disconnecting charger.** This will reduce risk of damage to electric plug and cord.

**Make sure that cord is located so that it will not be stepped on, tripped over, or otherwise subjected to damage or stress.**

**Do not use an extension cord unless it is absolutely necessary.** Use of improper extension cord could result in risk of fire, electric shock, or electrocution.

**Do not place any object on top of charger or place the charger on a soft surface that might block the ventilation slots and result in excessive internal heat.** Place the charger in a position away from any heat source. The charger is ventilated through slots in the top and the bottom of the housing.

**Do not operate charger with damaged cord or plug**—have them replaced immediately.

**Do not operate charger if it has received a sharp blow, been dropped, or otherwise damaged in any way.** Take it to an authorised service centre.

**Do not disassemble charger; take it to an authorised service centre when service or repair is required.** Incorrect reassembly may result in a risk of electric shock, electrocution or fire.

In case of damaged power supply cord the supply cord must be replaced immediately by the manufacturer, its service agent or similar qualified person to prevent any hazard.

Disconnect the charger from the outlet before attempting any cleaning. This will reduce the risk of electric shock. Removing the battery pack will not reduce this risk.

NEVER attempt to connect two chargers together.

> The charger is designed to operate on standard 230V household electrical power.

Do not attempt to use it on any other voltage. This does not apply to the vehicular charger.

## Charging a Battery

> Plug the charger into an appropriate outlet before inserting battery pack

> Insert the battery pack 7 into the charger, making sure the battery pack is fully seated in the charger. The green (charging) light will blink repeatedly indicating that the charging process has started.

> The completion of charge will be indicated by the green light remaining ON continuously. The battery pack is fully charged and may be used at this time or left in the charger. To remove the battery pack from the charger, push the battery release button 6 on the battery pack.

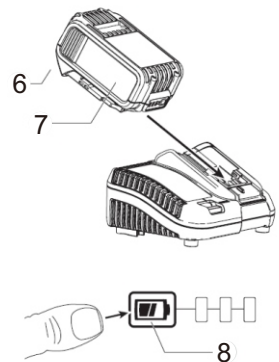

**NOTE:** To ensure maximum performance and life of lithium-ion battery packs, charge the battery pack fully before first use.

## Charge Indicators



> The green light will continue to blink, but a red indicator light will be lighting-off during this operation. Once the battery pack has reached an appropriate temperature, the red light will turn on and blink slowly . The charger will resume the charging procedure after the red light is turned off.

The compatible charger(s) will not charge a faulty battery pack. The charger will indicate faulty battery by illuminating the red light and blinking quickly.

**NOTE:** This could also mean a problem with a charger.

If the charger indicates a problem, take the charger and battery pack to be tested at an authorised service centre.

## Operation

> Assemble & Release Battery Pack

1.1 Assemble the fully charged battery pack as PIC.1

1.2 Push down button 6 and then pull out the battery pack from the main body of the machine.

> Power On & Off the Machine

2.1 Push on-off button 1 to position of I to start the machine. The LCD displays "00".

2.2 Push on-off button to position of 0 to power off the machine.

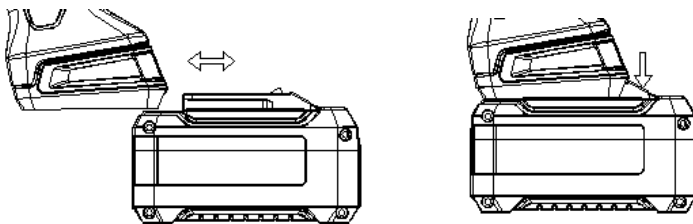

PIC.1

> Speed Adjustment

- 3.1 Increase the speed: Push speed increase button 5 after the machine is power on. The LCD display shows numbers of 20, 25, 30,35,40,45,48 when pushing the button, which means the speed steps of 2000rpm,2500rpm,3000rpm, 3500rpm,4000rpm,4500rpm,4800rpm relatively.
- 3.2 Decrease the speed: Push speed decrease button 3 after the machine is power on. The LCD display shows numbers of 20, 25, 30,35,40,45,48 when pushing the button, which means the speed steps of 2000rpm,2500rpm,3000rpm, 3500rpm,4000rpm,4500rpm,4800rpm relatively.

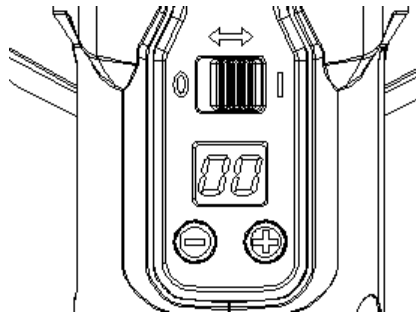

PIC.2



# LCD Display Instructions

## 1.Speed Selections Instruction

Speed Selections			
Selections	Numbers Shown on the Screen	Speed Indicated	Remark
0	00	No Speed	Power ON
1	20	2000±10%	
2	25	2500±10%	
3	30	3000±10%	
4	35	3500±10%	
5	40	4000±10%	
6	45	4500±10%	
7	48	4800-10%	The Highest Speed

## 2.Errors Displayed Instruction

Errors Displayed Instruction			
Error No	Phenomenon	Possible Reasons	Solutions
E1	E1	Over load protection: 1. over loaded(the working electricity current more than 50A±4A ≤500mS) 2. The machine is damaged.	<ol style="list-style-type: none"> <li>1. Power off the machine.</li> <li>2. Re-start the machine</li> <li>3. If above 2 actions are not workable, please send the machine to the professionals for repairing.</li> </ol>
E3	E3	Power-on Failure protection: 1. Some outside reason leads the motor doesn't work 2. The machine is damaged.	<ol style="list-style-type: none"> <li>1. Power off the machine.</li> <li>2. Re-start the machine</li> <li>3. If above 2 actions are not workable, please send the machine to the professionals for repairing.</li> </ol>
E4	E4	Block Torsion Protection : 1. Over loaded ; 2. The machine is damaged.	<ol style="list-style-type: none"> <li>1. Power off the machine.</li> <li>2. Re-start the machine</li> <li>3. If above 2 actions are not workable, please send the machine to the professionals for repairing.</li> </ol>
E5	E5	Over heat protection: The machine is running with high loading for long time. And the temperature of MOS arrived more than 100°C, which leads the machine stops running.	Power off the machine and cool the machine for 0.5h. The machine can be re-powered on when MOS temperature decreases to 60°C.
E6	E6	Lack of Voltage Protection: The volume of electricity charge is too lower than 14V±0.5V.	Charge the battery and use the fully charged battery.

E7	E7	Hardware Protection: machine fault	<ol style="list-style-type: none"> <li>1. Power off the machine.</li> <li>2. Re-start the machine</li> <li>3. If above 2 actions are not workable, please send the machine to the professionals for repairing.</li> </ol>
E8	E8	Motor protection: machine fault	<ol style="list-style-type: none"> <li>1. Power off the machine.</li> <li>2. Re-start the machine</li> <li>3. If above 2 actions are not workable, please send the machine to the professionals for repairing.</li> </ol>
E9	E9	Over Voltage protection: 1. Battery voltage more than 30V	<ol style="list-style-type: none"> <li>1. Check the voltage of the battery is normal or not. It should be <math>\leq 21V</math></li> <li>2. Use the qualified battery.</li> </ol>

## MAINTENANCE / SERVICE

- Protect the tool from impact, shock and grease
- Always keep tool and cord clean (especially ventilation slots L)  
! disconnect the plug before cleaning  
! do not attempt to clean ventilation slots by inserting pointed objects through openings

## ENVIRONMENT

- Do not dispose of electric tools, accessories and packaging together with household waste material (only for EU countries)  
- in observance of European Directive on waste of electric and electronic equipment and its implementation in accordance with national law, electric tools that have reached the end of their life must be collected separately and returned to an environmentally compatible recycling facility

On the product, the rating label and within these instructions you will find among others the following symbols and abbreviations. Familiarize yourself with them to reduce hazards like personal injuries and damage to property.

V~	Volt, (alternating voltage)	mm	Millimetre
Hz	Hertz	kg	Kilogram
W	Watt	dB(A)	Decibel (A-rated)
/min or min <sup>-1</sup>	Per minute	m/s <sup>2</sup>	Metres per seconds squared



Lock / to tighten or secure.



Unlock / to loosen.



Note / Remark.



Caution / Warning.



Read the instruction manual.



Wear hearing protection.



Wear eye protection.



Wear a dust mask.



Wear protective gloves.



Wear protective, slip-resistant footwear.



Switch the product off and disconnect it from the power supply before assembly, cleaning, adjustments, maintenance, storage and transportation.



The product complies with the applicable European directives and an evaluation method of conformity for these directives was done.



WEEE symbol. Waste electrical products should not be disposed of with household waste. Please recycle where facilities exist. Check with your Local Authority or local store for recycling advice.

